

BILL OF MATERIAL: 08864-101

#	DESCRIPTION	MAT	P/N
1	COVER	AL	08864-201A
2	DOG HUB ASSY	AL	08864-102A
3	(4) DOG ARM	AL	08864-203A
4	GASKET	NEO	08864-701A
5	BUSHING	SS	08864-804A
6	O-RING	NEO	08864-702A
7	T-HANDLE	SS	08864-401A
8	DECK RING AL	AL	08861-203A
8	DECK RING ST	ST	08861-207A
9	ESCAPE HANDLE	AL	08864-213A
10	HANDLE PIN	SS	08864-801A
11	(4) THREADED POST	SS	08864-802A
12	(4) WASHER	SS	08864-805A
13	(4) WASHER	UP	08864-803A
14	(4) NYLOCK NUT M10	SS	08864-807A

MATERIAL KEY

AL - ALUMINUM
ST - GALV. STEEL
SS - STAINLESS STEEL
UP - UHMW POLY
NEO - NEOPRENE

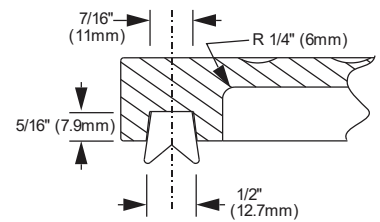

GASKET GROOVE, SECTION B:B

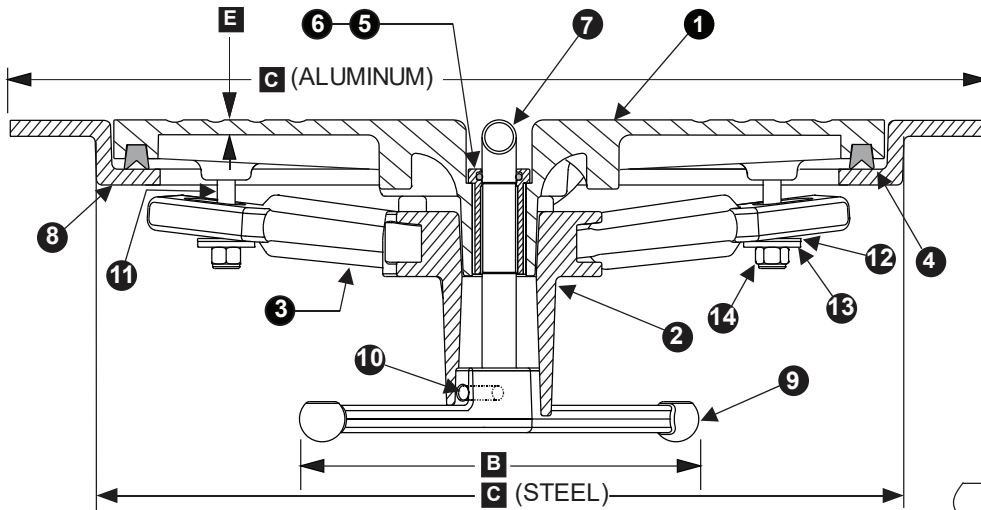

SECTION A:A

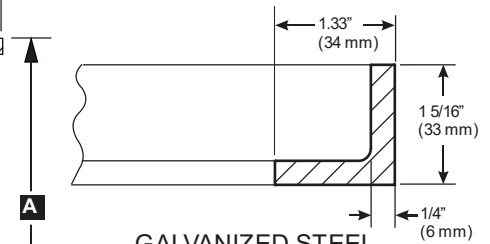

GALVANIZED STEEL DECK RING

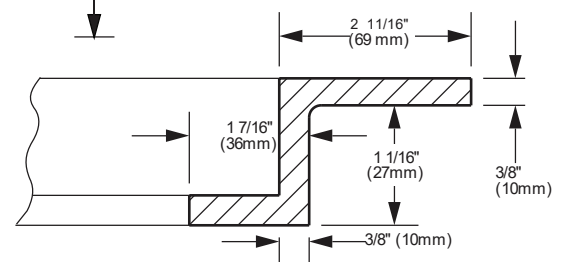

CAST ALUMINUM DECK RING

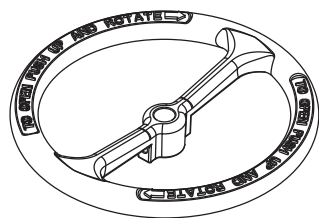

OPTIONAL ESCAPE HANDWHEEL (REPLACES ESCAPE HANDLE)

IMPORTANT: WHEN ORDERING, PLEASE SPECIFY OUTSIDE DIAMETER (C) OR CLEAR OPENING (D). UNITS ARE IDENTIFIED BY CLEAR OPENING.

HATCH WEIGHTS LBS. (KGS)

Model Number	BFHQTH15X24
Material	AL ST
Cover	25.8 (11.7) N/A
Deck Ring	9 (4.1) 12 (5.4)

DIMENSIONS INCHES (mm)

Model Number	A	B	C (AL)	C (ST)	D	E
BFHQTH15X24	7 1/16 (179)	12 (305)	30 7/16 x 21 7/16 (777 x 548)	26 1/2 x 17 1/2 (673 x 445)	24 x 15 (610 x 381)	1/4 (6)

BAIER Marine Company, Inc.
 1-800-455-3917
 206-632-2441 (FAX)
 sales@baiermarine.com

BAIER FLUSH HATCH
 LIFT-OUT MULTI-DOGGED TYPE
 WITH BUILT-IN T-HANDLE
 TYPE "D" QUICK ACTING
 POSITIVE LOCK
MODEL BFHQTH15X24